

# DRYWELLS



# PALLETTE STONE CORP.

Precast Product Division | 373 Washington Street, Saratoga Springs, New York 12866

Phone: (518) 584-5891 | Fax (518) 584-2622 | www.dacollins.com

## 4'-0" I.D. DRYWELL

### NOTES:

CONCRETE: 4000 PSI

REINFORCEMENT: GR 60

ENTRAINED AIR: 5.0% - 9.0%

AASHTO H-20 LL

### THICKNESSES:

WALLS - 4"

ROOF SLAB - 6" H20 LL

### WEIGHTS:

4' HIGH BARREL SECTION - 2722 LB

2' HIGH BARREL SECTION - 1361 LB

TRAFFIC TOP - 1285 LB

FOOTING RING - 1370 LB

STANDARD 22"Ø  
CONCENTRIC PLUG OTHER  
SIZES/ORIENTATIONS  
AVAILABLE

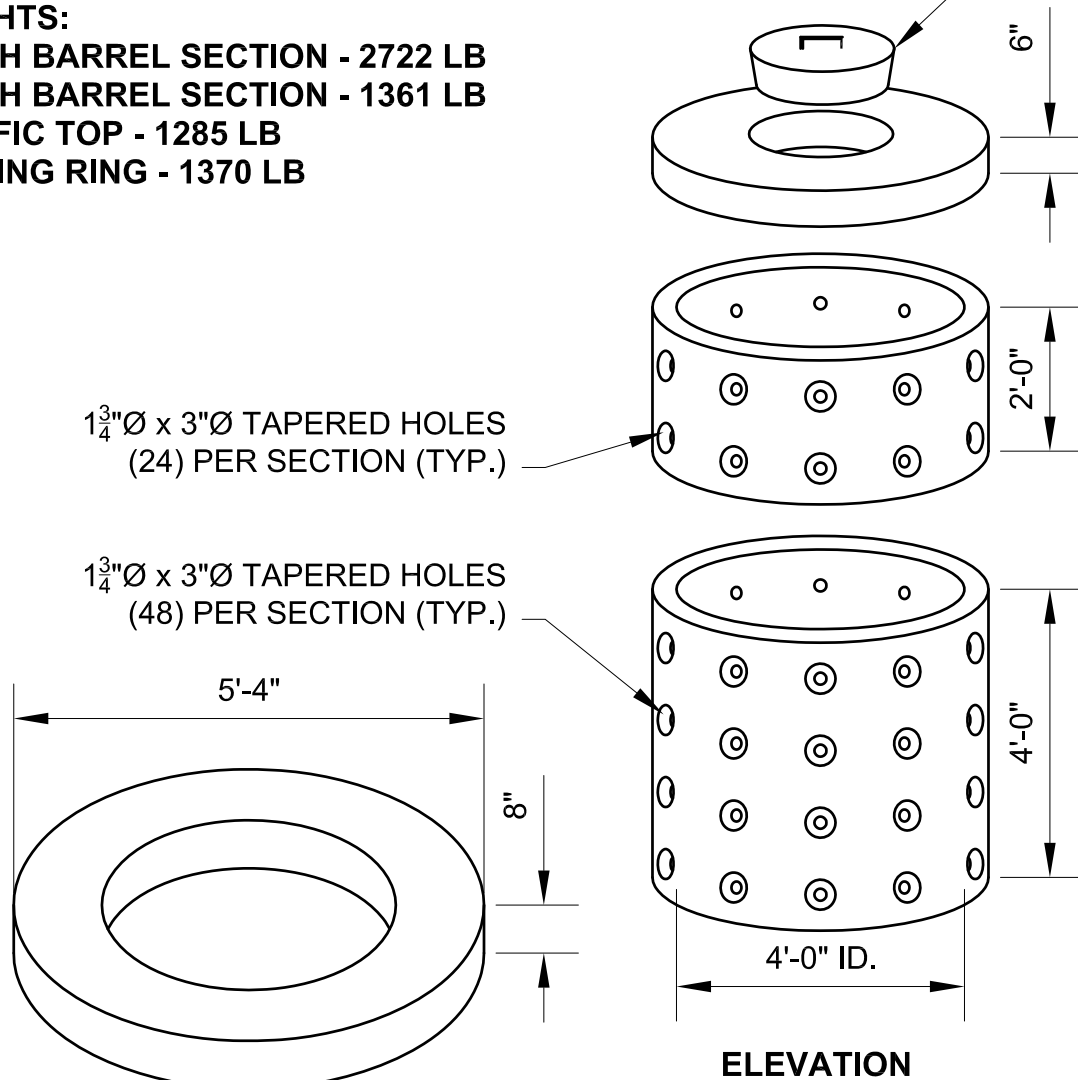

FOOTING RING

ELEVATION

# PALLETTE STONE CORP.

Precast Product Division | 373 Washington Street, Saratoga Springs, New York 12866

Phone: (518) 584-5891 | Fax (518) 584-2622 | www.dacollins.com

## 6'-0" O.D. DRYWELL

### NOTES:

CONCRETE: 4000 PSI

REINFORCEMENT: GR 60

ENTRAINED AIR: 5.0% - 9.0%

AASHTO H-20 LL

### THICKNESSES:

WALLS - 4"

ROOF SLAB - 8" H20 LL

### WEIGHTS:

4' HIGH BARREL SECTION - 3560 LB

TRAFFIC TOP - 2830 LB

FOOTING RING - 2000 LB

STANDARD 22"Ø  
CONCENTRIC PLUG OTHER  
SIZES/ORIENTATIONS  
AVAILABLE

$1\frac{3}{4}$ "Ø x 3"Ø TAPERED HOLES  
(124) PER SECTION (TYP.)

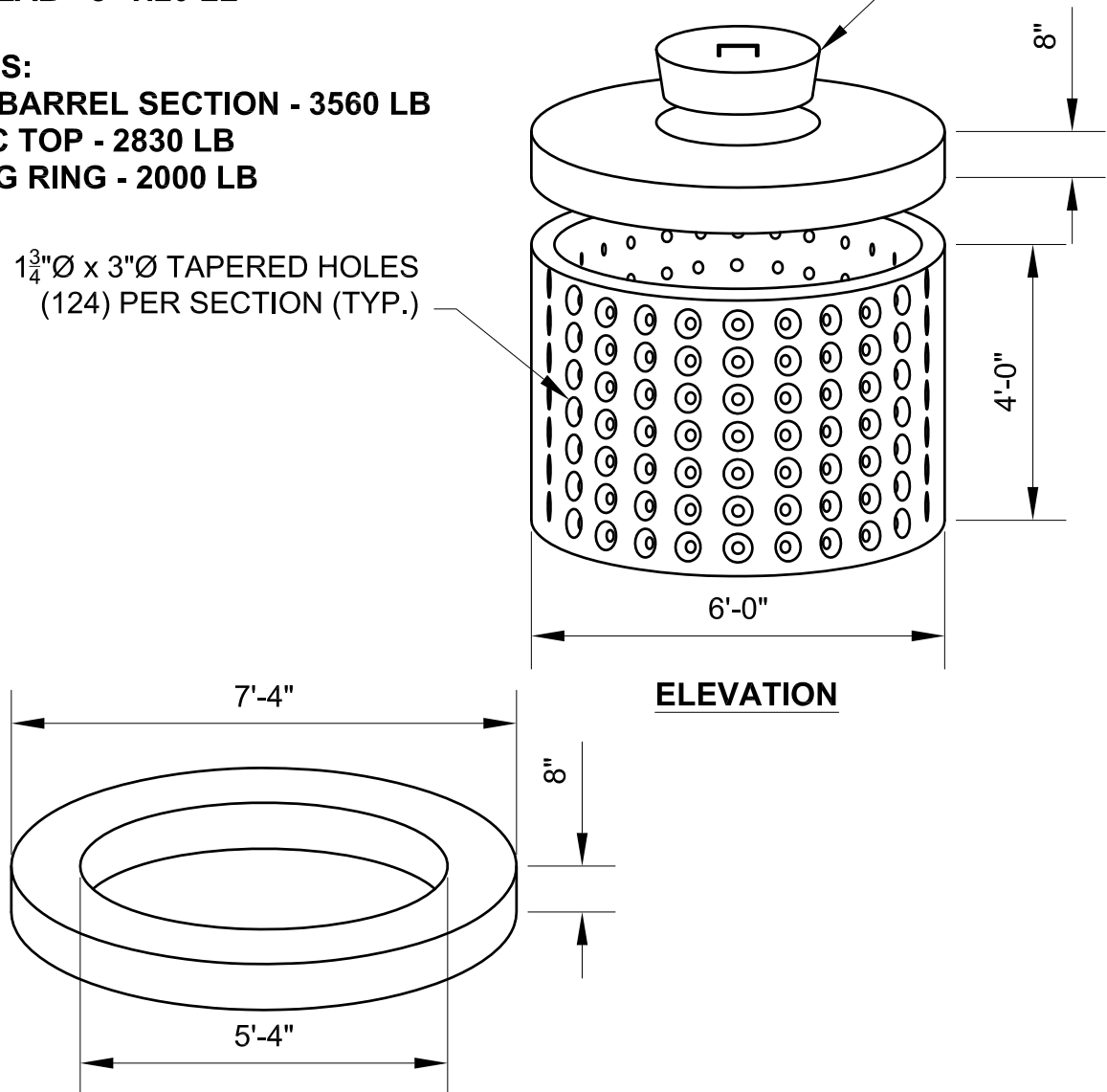

ELEVATION

ELEVATION

# PALLETTE STONE CORP.

Precast Product Division | 373 Washington Street, Saratoga Springs, New York 12866

Phone: (518) 584-5891 | Fax (518) 584-2622 | www.dacollins.com

## 8'-0" O.D. DRYWELL

### NOTES:

CONCRETE: 4000 PSI

REINFORCEMENT: GR 60

ENTRAINED AIR: 5.0% - 9.0%

AASHTO H-20 LL

### THICKNESSES:

WALLS - 4"

ROOF SLAB - 8" H20 LL

ROOF SLAB - 6" NON-TRAFFIC (300 PSF)

### WEIGHTS:

4' HIGH BARREL SECTION - 4800 LB

2' HIGH BARREL SECTION - 2400 LB

TRAFFIC TOP - 5050 LB

NON-TRAFFIC TOP - 3800 LB

1" x 6" TAPERED HOLES (91)  
PER 4' SECTION

OR

1 $\frac{3}{4}$ " $\varnothing$  x 3"  $\varnothing$  TAPERED HOLES  
(185) PER 4' SECTION  
(74) PER 2' SECTION

STANDARD 22"  $\varnothing$   
CONCENTRIC PLUG OTHER  
SIZES/ORIENTATIONS  
AVAILABLE

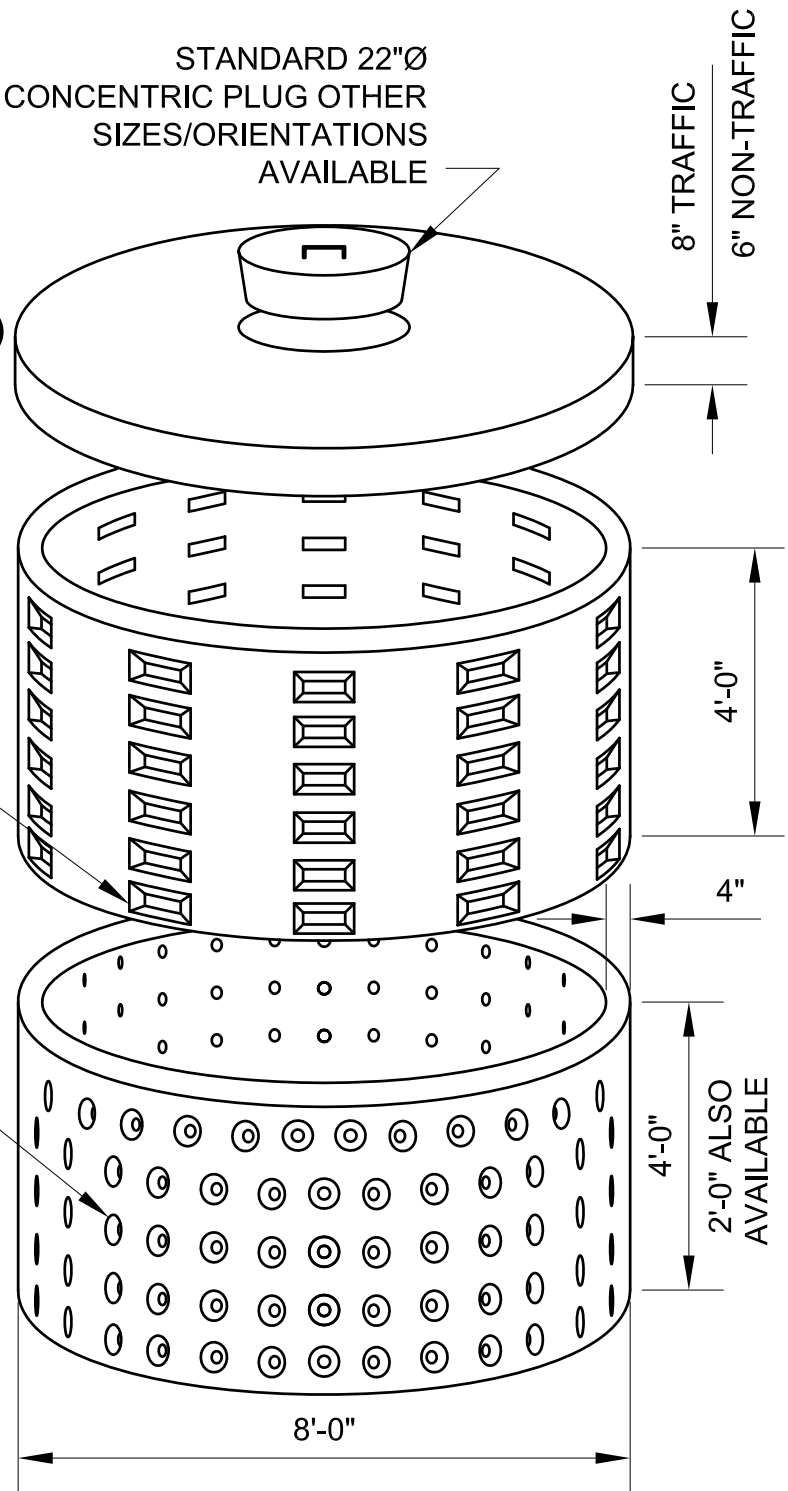

**ELEVATION**

# PALLETTE STONE CORP.

Precast Product Division | 373 Washington Street, Saratoga Springs, New York 12866

Phone: (518) 584-5891 | Fax (518) 584-2622 | [www.dacollins.com](http://www.dacollins.com)

## 8'-0" O.D. DRYWELL FOOTING RING

### NOTES:

CONCRETE: 4000 PSI

REINFORCEMENT: GR 60

ENTRAINED AIR: 5.0% - 9.0%

AASHTO H-20 LL

WEIGHT: 1.2 TONS

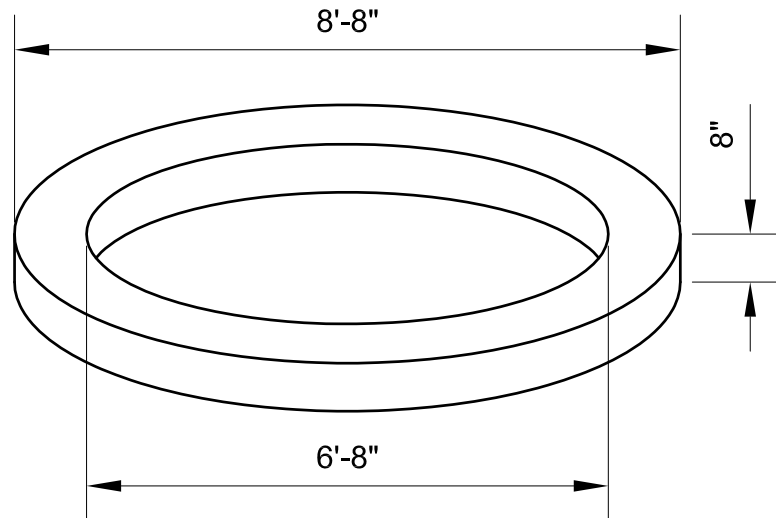

ELEVATION