

# OTHER



# PALLETTE STONE CORP.

Precast Product Division | 373 Washington Street, Saratoga Springs, New York 12866

Phone: (518) 584-5891 | Fax (518) 584-2622 | [www.dacollins.com](http://www.dacollins.com)

## CUSTOM VAULTS - LARGE TANKS

### NOTES:

CONCRETE: 4000-5000 PSI

REINFORCEMENT: ASTM A615 GR 60

ENTRAINED AIR: 5.0% - 9.0%

AASHTO H-20 LL

### THICKNESSES:

AS REQUIRED

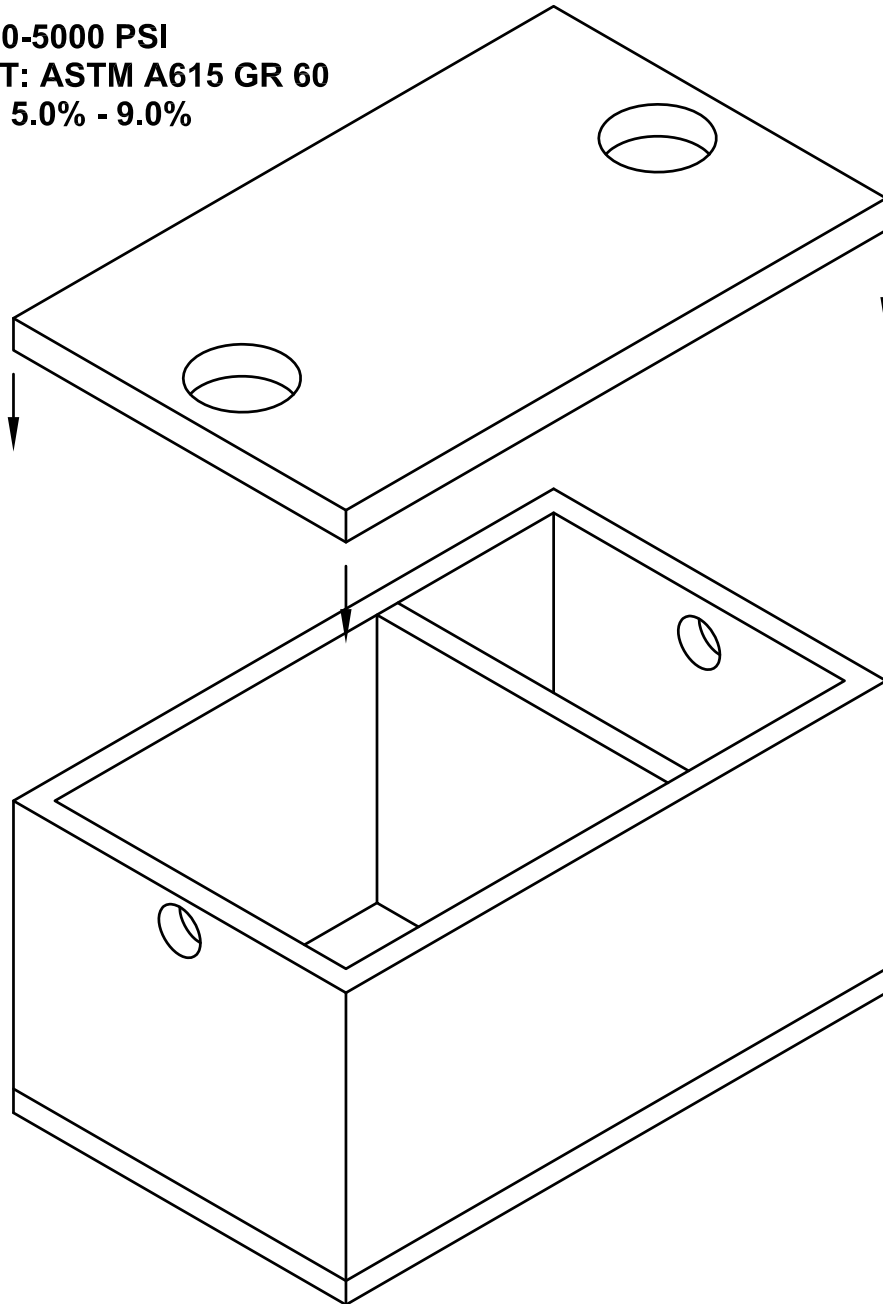

SEPTIC TANK SHOWN

SIZES FROM 750 GALLON TO 10,000 GALLON AVAILABLE UPON REQUEST

# PALLETTE STONE CORP.

Precast Product Division | 373 Washington Street, Saratoga Springs, New York 12866

Phone: (518) 584-5891 | Fax (518) 584-2622 | [www.dacollins.com](http://www.dacollins.com)

## TEMPORARY BARRIER

### NOTES:

CONCRETE: 3100 PSI

REINFORCEMENT: ASTM A615 GR 60

ENTRAINED AIR: 5.0% - 9.0%

8 TON BURKE LIFT ANCHORS

8 TON RING CLUTCH REQUIRED

MANUFACTURED PER NYSDOT  
STANDARD SHEETS

END CONNECTION HARDWARE  
INCLUDED

WEIGHT: 4 TONS (20' SECTION)

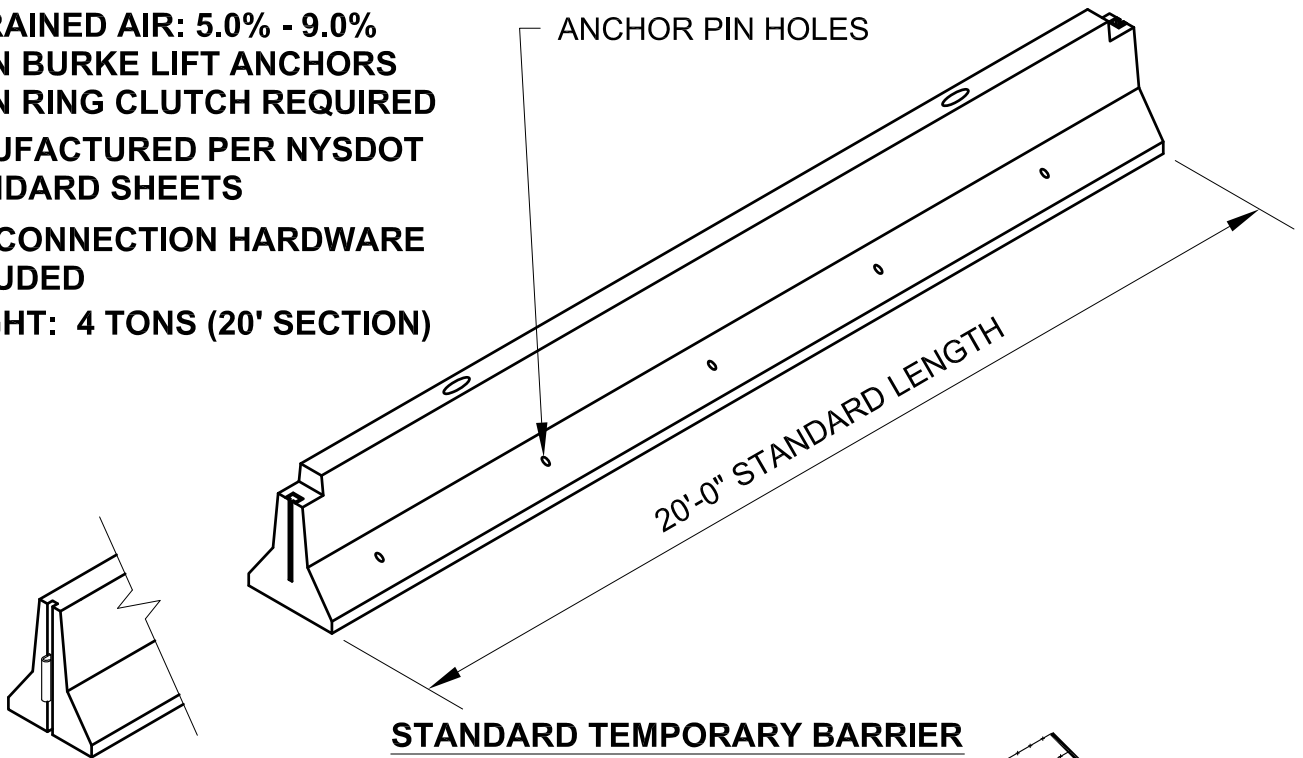

**STANDARD TEMPORARY BARRIER**

### ALTERNATE END CONNECTION NYSDOT APPROVED

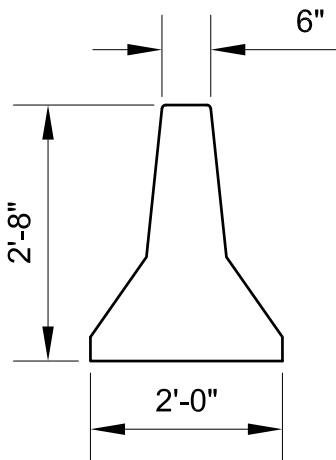

**TYPICAL CROSS SECTION**

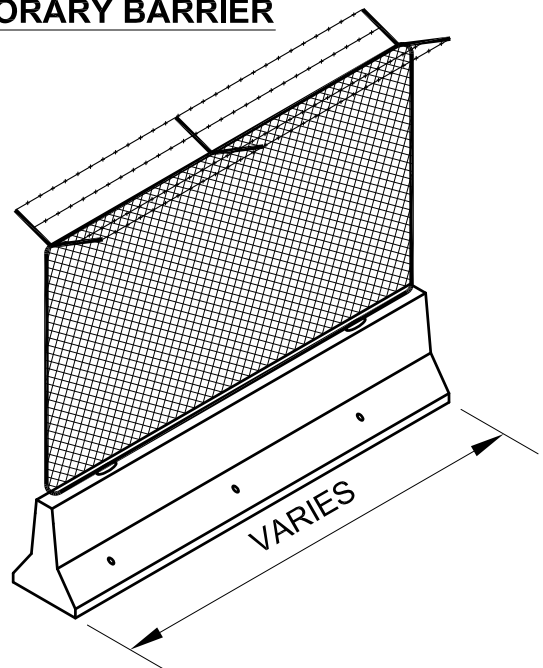

**OTHER CONFIGURATIONS AVAILABLE**

# PALLETTE STONE CORP.

Precast Product Division | 373 Washington Street, Saratoga Springs, New York 12866

Phone: (518) 584-5891 | Fax (518) 584-2622 | [www.dacollins.com](http://www.dacollins.com)

## NEW YORK STATE DOT MATERIALS

**PALLETTE STONE CORP. IS APPROVED FOR PRODUCTION UNDER NYSDOT MATERIALS BUREAU QC/QA PROGRAM. FOR MORE INFORMATION SEE: [www.dot.state.ny.us](http://www.dot.state.ny.us)**

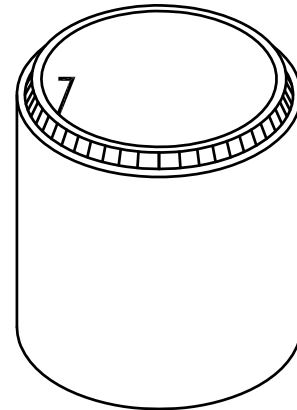
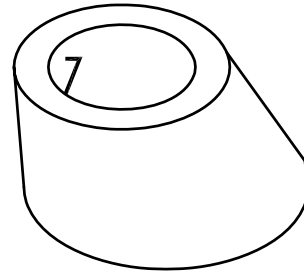
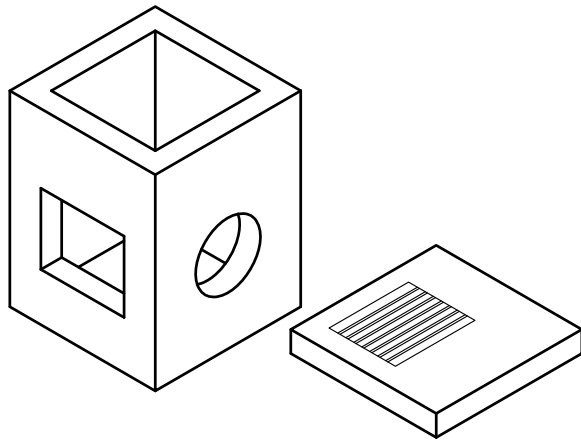

### RECTANGULAR OR ROUND DRAINAGE STRUCTURES

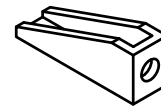
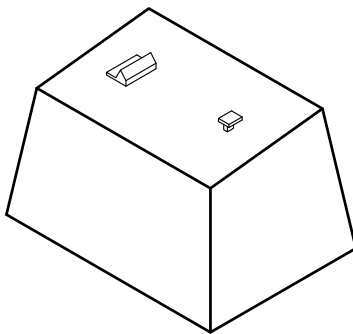

### PRECAST GUIDERAIL ANCHORS

### LATERAL OUTLET HEADWALLS

# PALLETTE STONE CORP.

Precast Product Division | 373 Washington Street, Saratoga Springs, New York 12866

Phone: (518) 584-5891 | Fax (518) 584-2622 | www.dacollins.com

## 6' TUFF STOP BUMPER

CONCRETE: 4000 PSI  
REINFORCEMENT: ASTM A615, GRADE 60  
ENTRAINED AIR: 5.0% - 8.0%  
WEIGHT: APPROXIMATELY 125 LBS  
AVAILABLE COLORS: SAFETY YELLOW  
HANDICAP BLUE

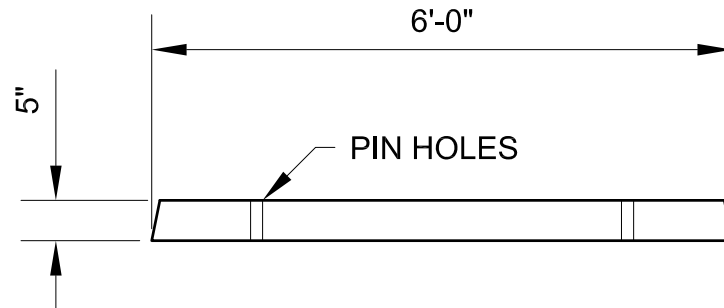

SIDE ELEVATION

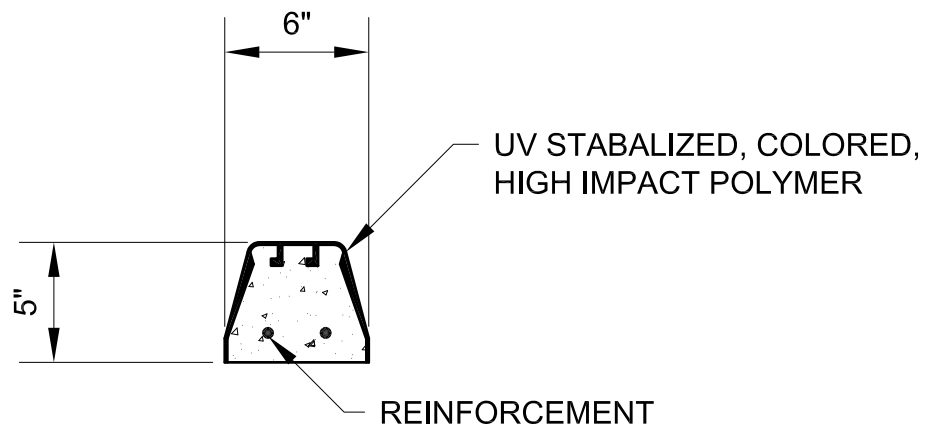

TYPICAL SECTION